



DGE Inc.

Computer Aided Design and Lab Services

Overview

DGE offers various Computer Aided Design (CAD) and Engineering Lab services. Our staff can provide finished drawings created from a customer's sketch, develop and assemble printed circuit boards from a customer's schematic, or handle complete box builds including documentation and system testing.

The primary CAD packages used are AutoCAD for mechanical design and Mentor Graphics PADS for PCB Design. Besides the primary outputs provided by these CAD packages, PDF, DXF and other output types can be supplied at the customer's request.

Our staff is IPC certified (Interconnecting and Packaging Electronic Circuits) and ADDA certified (American Design And Drafting Association). The customer will be provided with a complete set of hard copy and electronic copy of all the documentation required for his/her project. Once your project has been documented, our Engineering Lab can assist in the fabrication and assembly of any prototypes you may need.

Electrical Capabilities

- Schematic Entry
- PCB Design
- Quick Turn PCB
- Cable Design and Drawings

Mechanical Capabilities

- Mechanical Design and Engineering
- Mechanical Drafting
- Machine Shop
- Solid Modeling

Engineering Lab Capabilities

- PCB Assembly
- Cable Assembly
- System Prototype Assembly
- Sensor Prototyping Service
- Temperature Testing
- Box Builds

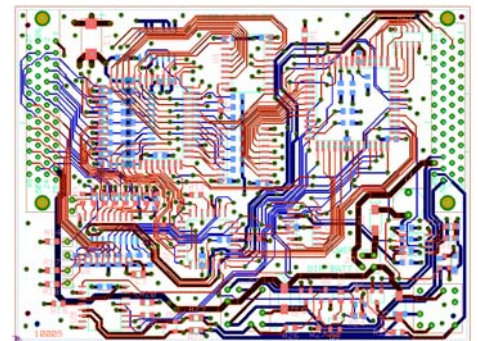
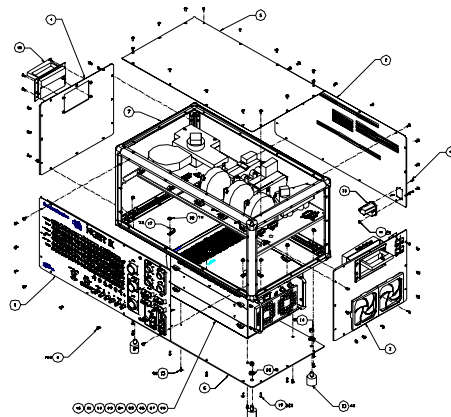

For more information on any of the products or services offered by DGE Inc., please send an e-mail to sales@dgeinc.com.

DGE Inc.

2870 Technology Drive Rochester Hills, MI 48309

Phone: 248.293.1300 Fax: 248.293.1309